

6 mm Square Dustproof Ceramic Trimmer Potentiometers  
(Cermet, Radial Taping)

Type: **EVMAAS/EVMAES**  
**(Radial Taping)**  
**EVMAAG/EVMAEG/EVMAHG/EVMAJG/EVMASG**  
**(Bulk)**

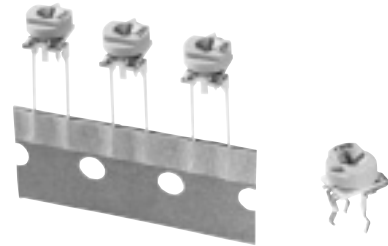

### ■ Features

- High reliability due to cermet element
- Excellent automatic insertion due to strong lead terminals
- Available for automatic adjustment due to slot & taper shape suitable for screwdriver
- Dustproof type with electrically activated wiper enclosed in an insulated rotor cap
- Conforms to JIS C5260-1:1999

### ■ Recommended Applications

- Audio/visual, office, and communication equipment
- General electronic equipment

### ■ Explanation of Part Numbers

1	2	3	4	5	6	7	8	9	10	11	12
E	V	M	A	A	S	A	0	0	B	5	2
Product Code			Type/Structure (AA, AE, AH, AJ, AS)				Taper & Resistance Example : B52=500 Ω				

Symbol	Packaging
SA00	Radial taping height 20 mm
SA01	Radial taping height 21 mm
GA00	Bulk Standard

\*For part number details, refer to page ER151.

### ■ Specifications

	EVMAA□/EVMAHG/EVMAJG/EVMASG	EVMAE□ (Low Resistor Value)
Total Resistance Value	100 Ω to 1 MΩ	10 Ω to 500 Ω
Resistance Tolerance	±25 %	
Power Rating	0.3 W	0.5 W
Maximum Operating Voltage	100 V	$\sqrt{P \cdot R}$
Rotation Torque	2 to 30 mN·m	
Stopper Strength	50 mN·m min.	
Temperature Coefficient of Resistance	±200 × 10 <sup>-6</sup> /°C	· 10 Ω ≤ R ≤ 20 Ω ..... ±200 × 10 <sup>-6</sup> /°C · 20 Ω < R ≤ 200 Ω ..... ±150 × 10 <sup>-6</sup> /°C · 200 Ω < R ≤ 500 Ω ..... ±100 × 10 <sup>-6</sup> /°C

### ■ Minimum Quantity/Packing Unit

Part Number	Radial taping		Bulk	
	Quantity per Box	Packaging quantity	Quantity per pack	Packaging quantity
EVMAAS EVMAES	1000	10000	—	—
EVMAAG EVMAHG EVMAJG EVMASG	—	—	200	2000
EVMAEG	—	—	600	3000

■ Dimensions in mm (not to scale)

● Radial tapering

● 3-terminal, Top-adjust, Cross Slots ..... EVMAAS/EVMAES

**No. 1**

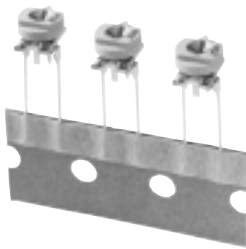
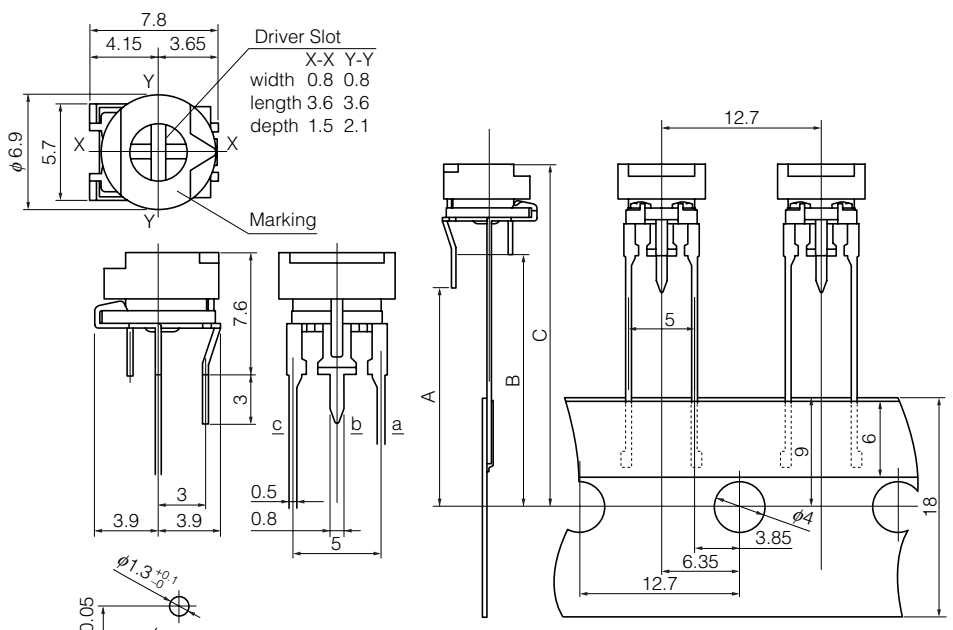
Driver Slot  
X-X Y-Y  
width 0.8 0.8  
length 3.6 3.6  
depth 1.5 2.1

Marking

(Recommended PWB Piercing Plan)

(Circuit diagram)

	A	B	C
A00	17	20	27.6
A01	18	21	28.6

Mass (Weight) : 420 mg/pc.

● Bulk

● 3-terminal, Top-adjust, Cross Slots ..... EVMAAG/EVMAEG

**No. 2**

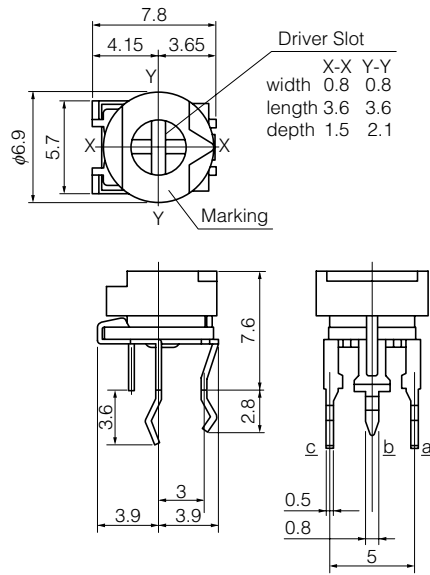
Driver Slot  
X-X Y-Y  
width 0.8 0.8  
length 3.6 3.6  
depth 1.5 2.1

Marking

(Recommended PWB Piercing Plan)

(Circuit diagram)

Mass (Weight) : 420 mg/pc.

■ Dimensions in mm (not to scale)

● Bulk

● 3-terminal, Top-adjust, Cross Slots ..... EVMAHG

**No. 3**



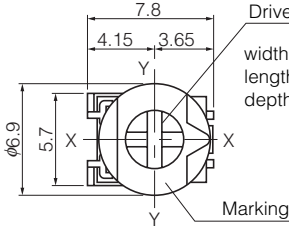

Driver Slot  
X-X Y-Y  
width 0.8 0.8  
length 3.6 3.6  
depth 1.5 2.1

Marking

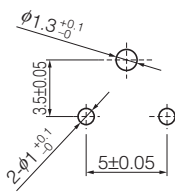

(Recommended PWB Piercing Plan)

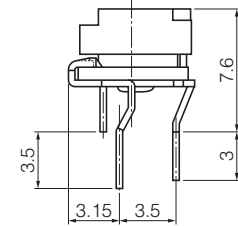

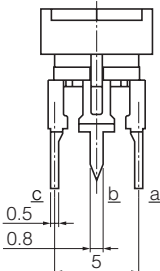

Mass (Weight) : 420 mg/pc.

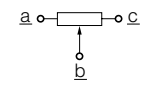

(Circuit diagram)

● 3-terminal, Top-adjust, Cross Slots ..... EVMAJG

**No. 4**



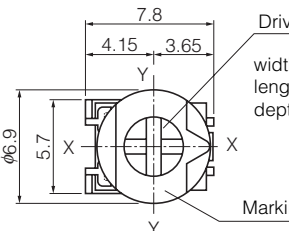

Driver Slot  
X-X Y-Y  
width 0.8 0.8  
length 3.6 3.6  
depth 1.5 2.1

Marking

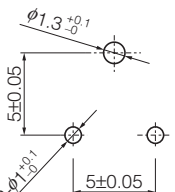

(Recommended PWB Piercing Plan)

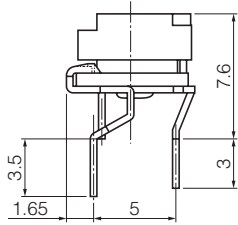

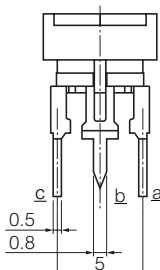

Mass (Weight) : 420 mg/pc.

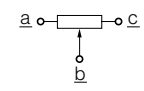

(Circuit diagram)

● 3-terminal, Top-adjust, Cross Slots ..... EVMASG

**No. 5**



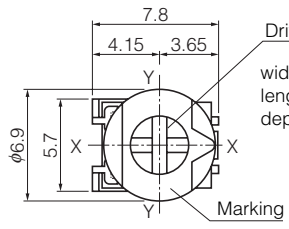

Driver Slot  
X-X Y-Y  
width 0.8 0.8  
length 3.6 3.6  
depth 1.5 2.1

Marking

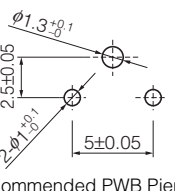

(Recommended PWB Piercing Plan)

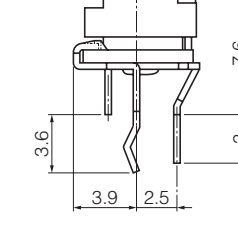

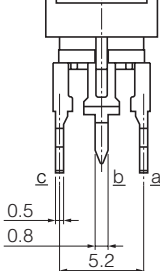

Mass (Weight) : 420 mg/pc.

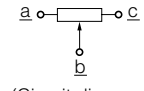

(Circuit diagram)

### ■ Explanation of Part Numbers

